



**INNOVATION, COMMITMENT, LEADERSHIP**

## **OPEN HEAD STEEL PAILS**



ICL IS A LEADING PROVIDER of premium quality open head steel pails to the food, construction materials, chemical, driveway sealer, roofing products and coatings industries. Our pails are produced in a wide range of sizes, in both standard and UN certified packages, from high quality cold rolled steel and can be matched to a range of covers that meet our customers' requirements for liquid or powder applications.

The value of ICL products begins at the design stage, where no detail is overlooked and is carried through every aspect of graphics, production, assembly and delivery.

Our capabilities include customization where required and attractive printing to enhance our customers' product offering.

As a wholly integrated, ISO registered supplier, our enthusiastic hands-on approach has assured clients of the finest quality and service every day since 1916.





# OPEN HEAD STEEL PAILS

ICL'S OPEN HEAD STEEL PAILS are ideal for applications such as Food, Construction Materials, Chemicals, Driveway Sealers, Roofing Products and Coatings.

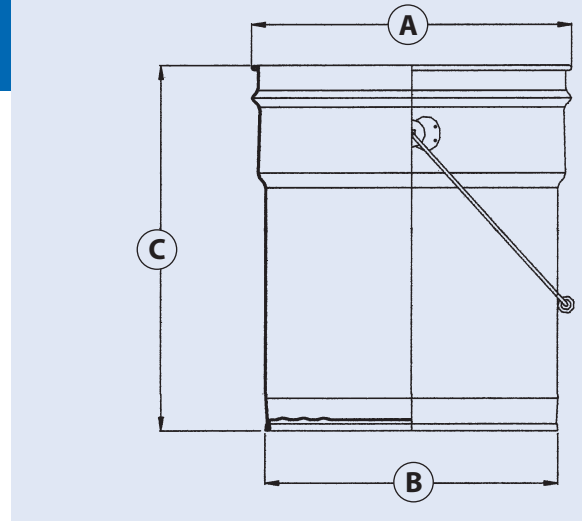

Pail	(A) Top Diameter	(B) Bottom Diameter	(C) Height	Gauge	Capacity	Weight (w/handle)
<b>TAPERED</b>						
<b>10 Litre</b>	11.8 in.	10.8 in.	8.2 in.	28	2.65 US gal./10 L	0.836 kg
<b>2.5 Imp. Gallon</b>	11.8 in.	10.8 in.	8.7 in.	28	3.0 US gal./11.3 L	0.881 kg
<b>3.5 US Gallon</b>	11.8 in.	10.8 in.	9.3 in.	26	3.5 US gal./13.2 L	1.139 kg
<b>5 US Gallon</b>	11.8 in.	10.8 in.	13.3 in.	26	5.0 US gal./18.9 L	1.354 kg
<b>20 Litre</b>	11.8 in.	10.8 in.	14.3 in.	26	5.3 US gal./20 L	1.433 kg
<b>5 Imp. Gallon</b>	11.8 in.	10.8 in.	15.9 in.	26	6.0 US gal./22.7 L	1.543 kg
<b>STRAIGHT SIDE</b>						
<b>5 US Gallon</b>	11.75 in.	10.8 in.	13.2 in.	26	5.0 US gal./18.9 L	1.354 kg
<b>20 Litre</b>	11.75 in.	10.8 in.	14.2 in.	26	5.3 US gal./20 L	1.433 kg

Above pails are available in other gauges. Dimensions and weights are approximate and subject to change without notice.

## FEATURES & BENEFITS

Corrugations at the top of the pail body have been designed to provide optimum structural strength.

As part of the process, each pail is tested for leakage using an in-line tester.

Handles are installed in a welded ear employing four projection welds for superior strength.

The exterior is available in a range of standard colours. Optional colours or multi-colour lithography are also available for an enhanced graphic image.

Interior protection is achieved with the application of coatings or linings compatible with customers' products.

ICL offers a full range of UN Open Head Steel Pails and Covers to meet various "Solid" and "Liquid" applications.

## COVERS

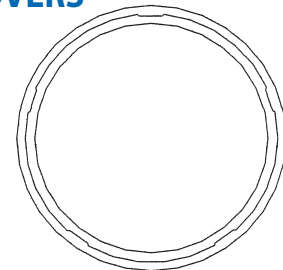

The following covers are compatible with the above pails:

- Regular 16 Lug Cover
- UN 16 Lug Cover
- Plastic Snap On Cover

*Call your nearest office to place an order or for more information.*

### Corporate Office Sales Office and Plant

INDUSTRIAL CONTAINERS LTD.  
100 North Queen Street  
Toronto, Ontario, Canada  
M8Z 2E2  
Tel: 416.231.5020  
416.231.2222 (Customer Service)  
Fax: 416.231.3586

### Sales Offices and Plants

INDUSTRIAL CONTAINERS LTD.  
27 Hansen Road South  
Brampton, Ontario, Canada  
L6W 3H7  
Tel: 905.453.8802  
905.453.8808 (Customer Service)  
Fax: 905.453.1518

INDUSTRIAL CONTAINERS LTD.  
2079, rue Pigeon  
La Salle, Quebec, Canada  
H8N 1A8  
Tel: 514.366.7700  
Fax: 514.366.9431

### Sales Offices and Warehousing

INDUSTRIAL CONTAINERS LTD.  
35 Calder Place  
St. Albert, Alberta, Canada  
T8N 5A6  
Tel: 780.458.5355  
Fax: 780.458.5699  
Tel: 800.667.5836 (AB, SK & MB)

INDUSTRIAL CONTAINERS LTD.  
Unit 105 - 84 North Bend Street  
Coquitlam, BC, Canada  
V3K 6H1  
Tel: 604.464.5579  
Fax: 604.464.5572



**INNOVATION, COMMITMENT, LEADERSHIP**

## **CLOSED HEAD STEEL PAILS**



ICL IS A LEADING PROVIDER of premium quality closed head steel pails to the food, construction materials, specialty chemical, solvent and coatings industries. Our pails are produced in a wide range of sizes, in both standard and UN certified packages, from high quality cold rolled steel.

The value of ICL products begins at the design stage, where no detail is overlooked and is carried through every aspect of graphics, production, assembly and delivery.

Our capabilities include customization where required and attractive printing to enhance our customers' product offering.

As a wholly integrated, ISO registered supplier, our enthusiastic hands-on approach has assured clients of the finest quality and service every day since 1916.





# CLOSED HEAD STEEL PAILS

ICL'S CLOSED HEAD STEEL PAILS are ideal for applications such as Food, Construction Materials, Specialty Chemicals, Solvents and Coatings.

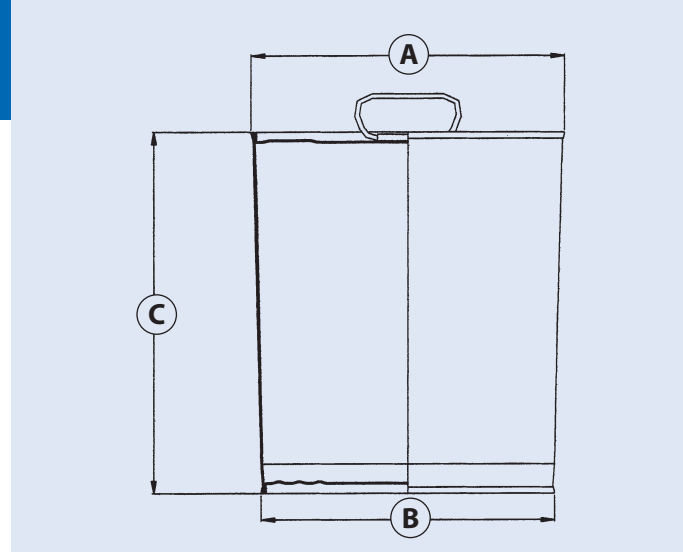

Pail	(A) Top Diameter	(B) Bottom Diameter	(C) Height	Gauge	Capacity	Weight (w/handle)
<b>10 Litre</b>	11.4 in.	10.8 in.	8.2 in.	28	2.65 US gal./10 L	1.052 kg
<b>3.0 US Gallon</b>	11.4 in.	10.8 in.	9.6 in.	28	3.0 US gal./11.3 L	1.228 kg
<b>5.0 US Gallon</b>	11.4 in.	10.8 in.	13.6 in.	28	5.0 US gal./18.9 L	1.487 kg
<b>20 Litre</b>	11.4 in.	10.8 in.	14.5 in.	28	5.3 US gal./20 L	1.464 kg
<b>5.0 Imp. Gallon</b>	11.4 in.	10.8 in.	15.9 in.	26	6.0 US gal./22.73 L	1.941 kg

Above pails are available in other gauges. Dimensions and weights are approximate and subject to change without notice.

## FEATURES & BENEFITS

ICL ensures the structural integrity of its product by testing each pail in-line for leakage.

The metal clip that holds the Saddle Type handle is secured to the head of the pail using four projection welds for superior strength.

The exterior is available in a range of standard colours. Optional colours or multi-colour lithography are also available for an enhanced graphic image.

Interior protection is achieved with the application of coatings or linings compatible with customers' products.

ICL offers a full range of UN Closed Head Steel Pails to meet various "Liquid" applications.

## FITTINGS

The following closures are available for closed head steel pails:

38 mm crimped on fitting, supplied loose

2" x 3/4" flange and plug drum closures installed

2 1/8" screw cap c/w inner seal installed

ICL provides precision holing in the top head to reduce the potential for metal fatigue in this critical area. Dust caps are available to prevent contamination during storage.

*Call your nearest office to place an order or for more information.*

### Corporate Office Sales Office and Plant

INDUSTRIAL CONTAINERS LTD.  
100 North Queen Street  
Toronto, Ontario, Canada  
M8Z 2E2  
Tel: 416.231.5020  
416.231.2222 (Customer Service)  
Fax: 416.231.3586

### Sales Offices and Plants

INDUSTRIAL CONTAINERS LTD.  
27 Hansen Road South  
Brampton, Ontario, Canada  
L6W 3H7  
Tel: 905.453.8802  
905.453.8808 (Customer Service)  
Fax: 905.453.1518

INDUSTRIAL CONTAINERS LTD.  
2079, rue Pigeon  
La Salle, Quebec, Canada  
H8N 1A8  
Tel: 514.366.7700  
Fax: 514.366.9431

### Sales Offices and Warehousing

INDUSTRIAL CONTAINERS LTD.  
35 Calder Place  
St. Albert, Alberta, Canada  
T8N 5A6  
Tel: 780.458.5355  
Fax: 780.458.5699  
Tel: 800.667.5836 (AB, SK & MB)

INDUSTRIAL CONTAINERS LTD.  
Unit 105 - 84 North Bend Street  
Coquitlam, BC, Canada  
V3K 6H1  
Tel: 604.464.5579  
Fax: 604.464.5572